

MVS-63

BS5163 IS NRS WEDGE GATE VALVE

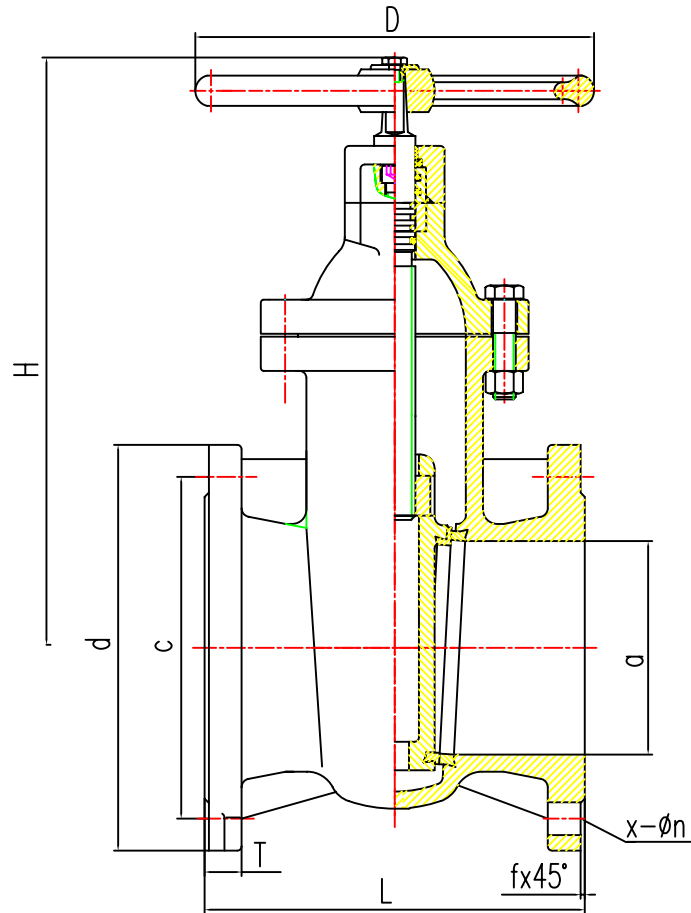

DN350-DN600

Test Pressures Body: 24 bar
 Test Pressures Seat: 17.6 bar

Material

NO	Part	Material
1	Body, Bonnet	Cast iron BS1452 220
2	Wedge, Glant	Cast iron BS1452 220
3	Handwheel	Cast iron BS1452 220
4	Stem	2Cr13
5	Stem nut	Brass
6	O Ring	NBR
7	Gasket	NBR
8	Seat ring	Bronze

Dimension: mm (BS4504-PN16)

SIZE	d	C	d	T	f	L	X-n	D	H	Wt?kg?
350	350	470	520	36	4	381	16-φ28	500	865	360
400	400	525	580	38	4	406	16-φ31	560	965	500
450	450	585	640	40	4	432	20-φ31	600	1070	620
500	500	650	715	42	4	457	20-φ34	650	1170	810
600	600	770	840	48	5	508	20-φ37	750	1400	1010

Pressure / Temperature Ratings	
Temperature (C)	0 to 120
Pressure (Bar)	16

Mechtech Valve Services,
 The Stenders, Mitcheldean,
 Glos. GL17 0ZE
 Tel: 01594 541717 Fax: 01594 541716

Mechtech Valve Services,
 33 Pennycress, Locks Heath,
 Southampton. Hants. SO31 6SY
 Tel: 01489 609609 Fax: 01489 609610

www.mechtechvalveservices.com

MVS-63 Datasheet

MVS-63-DS Rev 002
 30-Mar-2006

Copyright 2006