

Specification Standard Sheet		Flanger Facings: ASME B16.5 (6.4.5.3)
Shell Test Pressure	3.1	Serrated spiral finish having a resultant surface finish from 3.2 μ m to 6.3 μ m average roughness shall be furnished. The cutting tool employed should have an approximate 1.5mm or larger radius, there should be from 1.8 grooves/mm through 2.2 grooves/mm.
High Pressure Seal Test	2.2	
Low Pressure Seal Test	0.6	
Suitable Temperature	-29~425°C	
Suitable Medium	Water, Steam, Oil etc	

Nominal Diameter		Main Dimension(mm)						
inch	mm	d	D	b	L	H	ϕ W	
2"	50	50	165	16	203	328	200	
2 1/2"	65	63	184	16	216	360	250	
3"	80	76	203	16	241	373	280	
4"	100	100	229	19	292	400	300	

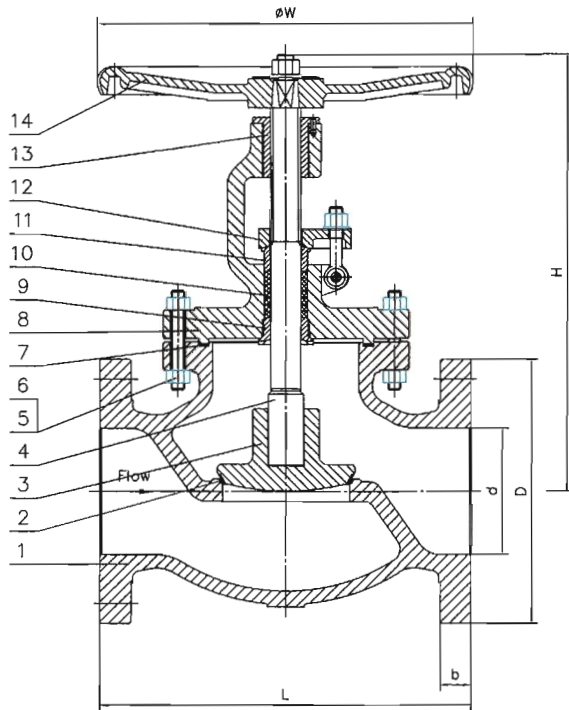

14	Hand Wheel	ASTM A536 60-40-18	
13	Stem Nut	Copper Alloy	
12	Gland Flange	ASTM A216 WCB	
11	Gland	ASTM A276 420	
10	Stem Packing	Flexible Graphite	
9	Backseat Bushing	ASTM A276 420	
8	Bonnet	ASTM A216 WCB	
7	Winded Gasket	Graphite+SS304	
6	Bonnet Nut	ASTM A194 2H	
5	Bonnet Bolt	ASTM A193 B7	
4	Stem	ASTM A182 F6a	
3	Disc	ASTM A105+13Cr	
2	Valve Seal	INT+13Cr	
1	Body	ASTM A216 WCB	
No	Parts Name	Parts Material	Remarks

GLOBE CHECK VALVE 150LB FF

Design and Manufacture	BS 1868
Face to Face Dimensions	ASME B16.10
Flanger Ends Dimensions	ASME B16.5
Inspection and Test	API 598

MVS(EXPORT)LTD