

50~300 PN16

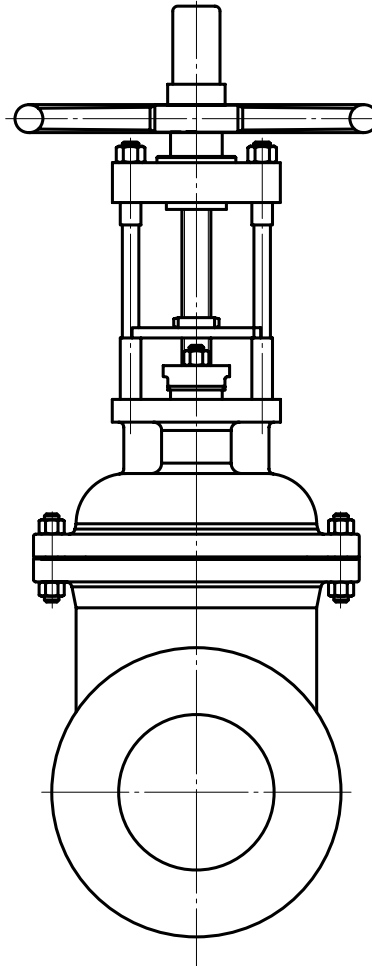
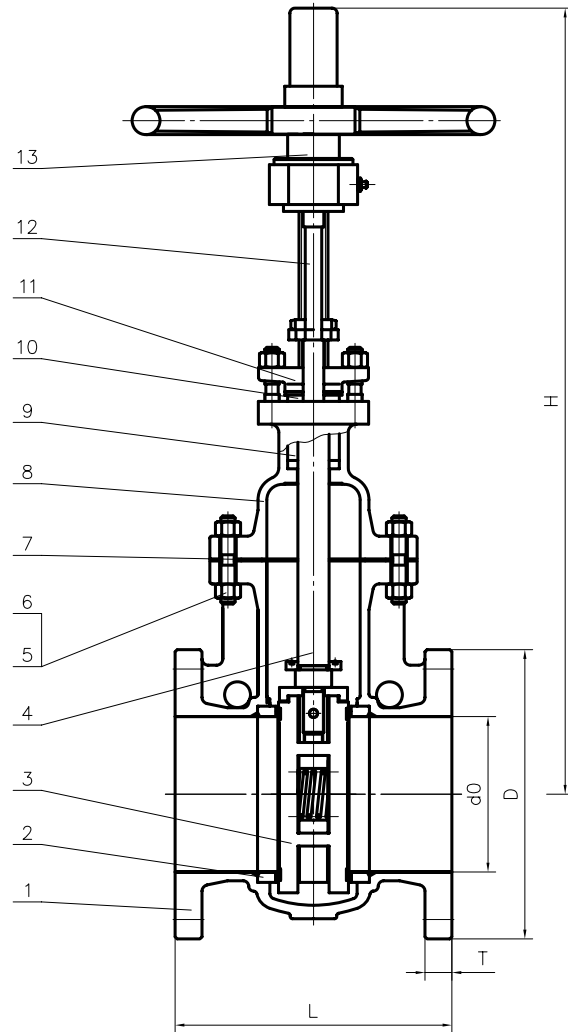

No.	Parts Name	Materials
1	Body	ASTM A216 Gr WCB
2	Seat	ASTM A105+STL-6#
3	Gate disc	ASTM A105+STL-6#
4	Stem	ASTM A182 F6
5	Stud Bolt	ASTM A193 B7
6	Nut	ASTM A194 2H
7	Gasket	304+Graphite
8	Bonnet	ASTM A216 Gr WCB
9	Packing	Graphite
10	Packing Sleeve	ASTM A182 F6
11	Packing Gland	ASTM A216 Gr WCB
12	Yoke	ASTM A29 1025
13	Stem Nut	ZCuAl10Fe3

DN	d0	L	H	D	T
50	49	178	370	165	18
65	62	190	405	185	18
80	74	203	450	200	20
100	100	229	570	220	20
125	125	254	615	250	22
150	150	267	710	285	22
200	201	292	890	340	26
250	252	330	1050	405	29
300	303	356	1250	460	32

Property Specification

- 1.Design and manufacturing as per API 6D
- 2.Face to face as per the chart as follows
- 3.Flange dimension as per BS4504 PN16
- 4.Inspection and testas per API 598

Mechtech Valve Services,
The Stenders, Mitcheldean,
Glos. GL17 0ZE
Tel: 01594 541717 Fax: 01594 541716

www.mechtechvalveservices.com

MECHTECH

MVS 2131

Parallel Slide Valve

50~300 PN16